

Range Hood

Installation & User Manual

NK30CB600W**/NK36CB600W**



SAMSUNG

Contents

Important Safety Instructions 3

Installation Requirements 7

General Specifications	7
Mounting Height	7
Venting Methods	8
Parts List	8
Sub-Parts List	9
Additional Purchase Accessories	9
Needed Parts list (Not Supplied)	9
Installation Clearances	10
Making a hole in the furniture	10

Installation 11

Setting the Location	11
Connecting the Vent System	12
Installing the Range Hood	13
Electrical Connection	14
Connect the filter support cable	17
Installing the Recirculation Kit	18
Electrical Connection	18

Range Hood Description 23

Range Hood Overview 23

Button panel	23
--------------	----

Using the Range Hood 24

Turning the Range Hood On or Off	24
Changing the operation mode	24

Activates/Deactivates Boost mode	24
Makeup Air	25
Using the lighting	25
Wi-Fi On/Off	25
Automatic operation to prevent range hood overheating	25
Entering AP(Access Point)	26
Delay off	26
Error indication	27
Bixby	27
Amazon Alexa & Google Assistant	27
Installation Guide	27

Cleaning and Maintenance 28

Cleaning the range hood	28
Cleaning the Filters	28
Replacing the LED Lamp	28

SmartThings app 29

Open Source Announcement	30
--------------------------	----

Troubleshooting 31

General	31
Hood Operation	31
Information codes	31

Warranty (USA) 32

Warranty (CANADA) 34

Important Safety Instructions

APPROVED FOR RESIDENTIAL APPLIANCES FOR RESIDENTIAL USE ONLY
READ AND SAVE THESE INSTRUCTIONS

PLEASE READ THE ENTIRE INSTALLATION GUIDE BEFORE PROCEEDING.
INSTALLATION MUST COMPLY WITH ALL LOCAL CODES.

IMPORTANT: Save these instructions for the local electrical inspector's use.

INSTALLER: Please leave these Instructions with this unit for the owner.

OWNER: Please retain these instructions for future reference.

Symbols used in this manual

WARNING

Hazards or unsafe practices that may result in severe personal injury or death.

CAUTION

Hazards or unsafe practices that may result in electric shock, personal injury, or property damage.

NOTE

Useful tips and instructions

These warning icons and symbols are here to prevent injury to you and others. Please follow them explicitly. After reading this section, keep it in a safe place for future reference.

WARNING

Turn off the power circuit in the service panel and lock out panel before wiring this appliance.

Installation requires a branch circuit of 120 VAC, 60 Hz, and 15 or 20 A.

WARNING

TO REDUCE THE RISK OF FIRE, ELECTRIC SHOCK, OR INJURY TO PERSONS, OBSERVE THE FOLLOWING PRECAUTIONS:

- Use this unit only in the manner intended by the manufacturer. If you have questions, contact the manufacturer.
- Before servicing or cleaning the unit, switch the power off at the service panel and lock the service panel to prevent the power from being switched on accidentally. If the service panel cannot be locked, securely fasten a prominent warning device, such as a tag, to the service panel.
- The installation work and electrical wiring must be done by qualified person(s) in accordance with all applicable codes and standards, including fire-rated construction.
- Sufficient air is needed for proper combustion and the exhausting of gases through the flue (chimney) of the fuel burning equipment to prevent backdrafting. Follow the heating equipment manufacturer's guidelines and safety standards, such as those published by the National Fire Protection Association (NFPA), the American Society for Heating, Refrigeration and Air Conditioning Engineers (ASHRAE), and the local code authorities.
- When cutting or drilling into the wall or ceiling, do not damage electrical wiring or other hidden utilities.
- Ducted fans must always be vented outdoors.

CAUTION

For general ventilating use only. Do not use to exhaust hazardous or explosive materials and vapors.

CAUTION

To reduce the risk of fire and to properly exhaust air, be sure to duct air outside - do not vent exhaust air into spaces enclosed within walls, ceilings, attics, or into crawl spaces or garages.

WARNING

TO REDUCE THE RISK OF FIRE, USE ONLY METAL DUCTWORK.

Important Safety Instructions

WARNING

TO REDUCE THE RISK OF A RANGE TOP GREASE FIRE:

- Never leave surface units unattended at high settings. Boilovers cause smoking and greasy spillovers that may ignite. Heat oils slowly on low or medium settings.
- Always turn the hood ON when cooking at high heat or when flambeing food (i.e. Crepes Suzette, Cherries Jubilee, Peppercorn Beef Flambé).
- Clean ventilating fans frequently. Grease should not be allowed to accumulate on the fan or filter.
- Use proper pan sizes. Always use cookware appropriate for the size of the surface element.

WARNING

TO REDUCE THE RISK OF INJURY TO PERSONS IN THE EVENT OF A RANGE TOP GREASE FIRE, OBSERVE THE FOLLOWING PRECAUTIONS:*

- SMOTHER FLAMES with a close fitting lid, cookie sheet, or metal tray, then turn off the burner. BE CAREFUL TO PREVENT BURNS. If the flames do not go out immediately, EVACUATE AND CALL THE FIRE DEPARTMENT.
- NEVER PICK UP A FLAMING PAN - you may get burned.
- DO NOT USE WATER, including wet dishcloths or towels - a violent steam explosion will result.
- Use an extinguisher ONLY if:
 - You know you have a class ABC extinguisher, and you already know how to operate it.
 - The fire is small and contained in the area where it started.
 - The fire department is being called.
 - You can fight the fire with your back to an exit.

* Based on "Kitchen Fire Safety Tips" published by NFPA.

WARNING

To reduce the risk of fire or electrical shock, do not use this fan with any solid-state speed control device.

WARNING

Do not let children near this appliance. Do not let children play with this appliance. Keep all packaging materials out of children's reach. Properly dispose the packaging materials after this appliance is unpacked.

Electrical Requirements

IMPORTANT

Observe all governing codes and ordinances.

It is the customer's responsibility:

To contact a qualified electrical installer.

To assure that the electrical installation is adequate and in conformance with the National Electrical Code, ANSI/NFPA 70 – latest edition*, or CSA Standards C22.1-94, Canadian Electrical Code, Part 1 and C22.2 No.0-M91 - latest edition** and all local codes and ordinances.

If codes permit and a separate ground wire is used, it is recommended that a qualified electrician determine that the ground path is adequate. A copy of the above code standards can be obtained from:

National Fire Protection Association

1 Batterymarch Park
Quincy, MA 02169-7471
CSA International
8501 East Pleasant Valley Road
Cleveland, OH 44131-5575

- A 120 volt, 60 Hz., AC only, 15-amp, fused electrical circuit is required.
- If the house has aluminum wiring, follow the procedure below:

1. Connect a section of solid copper wire to the pigtail leads.
2. Connect the aluminum wiring to the added section of copper wire using special connectors and/or tools designed and UL listed for joining copper to aluminum.

- Follow the electrical connector manufacturer's recommended procedure. Aluminum/copper connections must conform with local codes and industry accepted wiring practices.
- Wire sizes and connections must conform with the rating of the appliance as specified on the model/serial rating plate. The model/serial plate is located behind the filter on the rear wall of the range hood.
- Wire sizes must conform to the requirements of the National Electrical Code, ANSI/NFPA 70 (latest edition), or CSA Standards C22. 1-94, Canadian Electrical Code, Part 1 and C22.2 No. 0-M91 (latest edition and all local codes and ordinances).

GROUNDING INSTRUCTIONS

This appliance must be grounded. In the event of an electrical short circuit, grounding reduces the risk of electric shock by providing an escape wire for the electric current.

WARNING

- Improper grounding can result in a risk of electric shock.
- Consult a qualified electrician if the grounding instructions are not completely understood, or if doubt exists as to whether the appliance is properly grounded.
- Do not use an extension cord.

Venting Requirements (ducted models only)

- The vent system must terminate outdoors.
- Do not terminate the vent system in an attic or other enclosed area.
- Do not use a 4" (10.2 cm) laundry-type wall cap.
- Only use metal vents. Plastic vents are not recommended.
- The length of the vent system and the number of elbows should be kept to a minimum to provide efficient performance.

For the most efficient and quietest operation:

- Use no more than three 90° elbows.
- Make sure there is a minimum of 24" (61 cm) of straight vent between the elbows if more than one elbow is used.
- Do not install two elbows together.
- Use clamps to seal all joints in the vent system.
- The vent system must have a damper.
- Use caulking to seal the exterior wall or roof opening around the cap.
- The size of the vent should be uniform.

Venting Methods

To use the hood's top outlet to vent your hood, a 6" (15.2 cm) round vent system is required. To use the hood's rear outlet, a ¾" x 10" (8.25 x 25.4 cm) rectangular vent system is required. Neither of these vent systems are included and must be purchased separately.

NOTE

The vent system can terminate either through the roof or a wall. To vent through a wall, a 90° elbow is needed.

Mounting Height

Select a mounting height between a minimum of 24" (61 cm) for an electric cooking surface, a minimum of 27" (68.6 cm) for a gas cooking surface, and a suggested maximum of 36" (91.4 cm) above the range to the bottom of the hood.

Rear discharge

A 90° elbow may be installed immediately above the hood.

For Non-Vented (recirculating) Installations

If it is not possible to vent cooking fumes and vapors to the outside, the hood can be used in the non-vented (recirculating) version, fitting a charcoal filter and a plastic grid. Fumes and vapors are recycled through the recirculation grid.

Important Safety Instructions

1. FCC Notice

FCC STATEMENT:

The manufacturer is not responsible for any radio or TV interference caused by unauthorized modification to this microwave oven. It is the responsibility of the user to correct such interference.

This equipment has been tested and found to comply with the limits for a Class B digital device, pursuant to part 15 of the FCC Rules. These limits are designed to provide reasonable protection against harmful interference in a residential installation. This equipment generates, uses and can radiate radio frequency energy and, if not installed and used in accordance with the instructions, may cause harmful interference to radio communications. However, there is no guarantee that interference will not occur in a particular installation. If this equipment does cause harmful interference to radio or television reception, which can be determined by turning the equipment off and on, the user is encouraged to try to correct the interference by one or more of the following measures:

- Reorient or relocate the receiving antenna.
- Increase the separation between the equipment and receiver.
- Connect the equipment into an outlet on a circuit different from that to which the receiver is connected.
- Consult the dealer or an experienced radio/TV technician for help.

WARNING

Any changes or modifications to this unit not expressly approved by the party responsible for compliance could void the user's authority to operate the equipment.

FCC RF Exposure Requirements

This device complies with FCC RF radiation exposure limits set forth for an uncontrolled environment. The antenna(s) used for this transmitter must not be co-located or operating in conjunction with any other antenna or transmitter and must be installed to provide a separation distance of at least 20 cm from all persons.

2. IC Notice

This device contains licence-exempt transmitter(s)/receiver(s) that comply with Innovation, Science and Economic Development Canada's licence-exempt RSS(s). Operation is subject to the following two conditions:

- 1) This device may not cause interference.
 - 2) This device must accept any interference, including interference that may cause undesired operation of the device.
- CAN ICES(B)/NMB(B)

IC RADIATION EXPOSURE STATEMENT:

This equipment complies with IC RSS-102 radiation exposure limits set forth for an uncontrolled environment. This equipment should be installed and operated so there is at least 8 inches (20 cm) between the radiator and your body. This device and its antenna(s) must not be co-located or operated in conjunction with any other antenna or transmitter.

State of California Proposition 65 warning (US only)

WARNING

This product contains chemicals known to the State of California to cause cancer and birth defects or other reproductive harm.

Installation Requirements

General Specifications

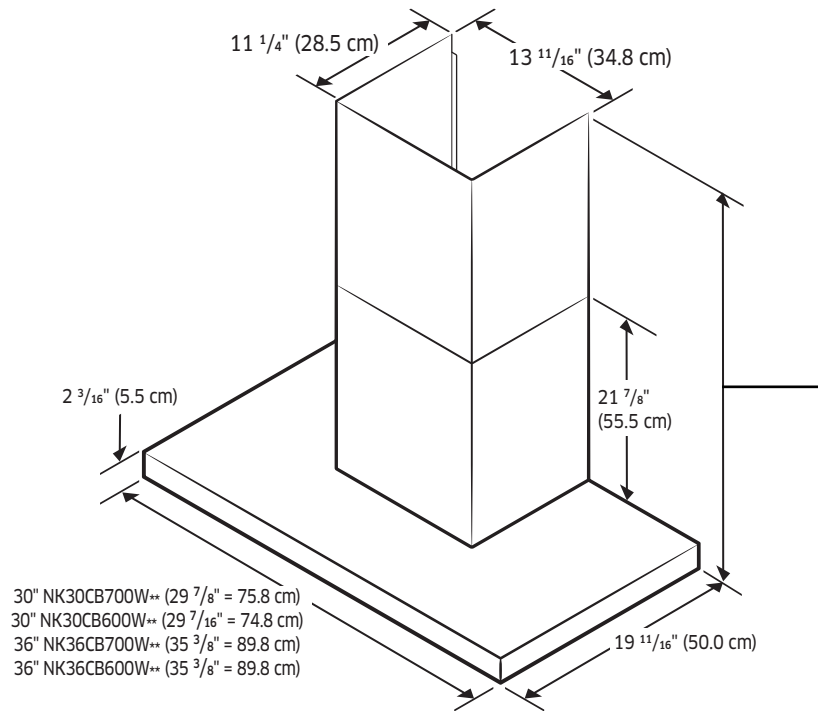

Vent Mode

Min $25 \frac{7}{16}''$ (64.6 cm)
 Max 42" (106.6 cm)

Vent Mode (Extension Kit)

Min 40" (101.6 cm)
 Max $71 \frac{1}{8}''$ (180.6 cm)

Recirculation Mode

Min $28 \frac{3}{8}''$ (72.0 cm)
 Max $44 \frac{1}{2}''$ (113.0 cm)

Recirculation Mode (Extension Kit)

Min $41 \frac{3}{4}''$ (106.0 cm)
 Max $72 \frac{7}{16}''$ (184.0 cm)

Mounting Height

⚠ CAUTION

- Be sure to check the mounting height before installing the product.
- The mounting height is measured from the top of the range to the upper cabinets. The mounting height for an electric cooking surface is measured from its glass cooktop as shown in the image on the left. For a gas cooking surface, the mounting height is measured from the top of the burning grates as shown in the image on the right.

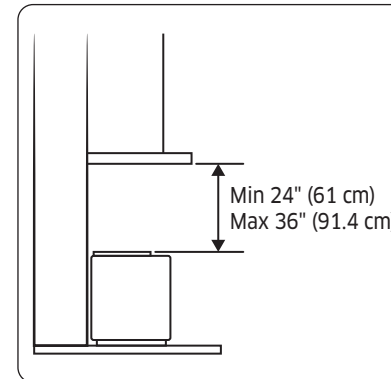

ELECTRIC RANGES

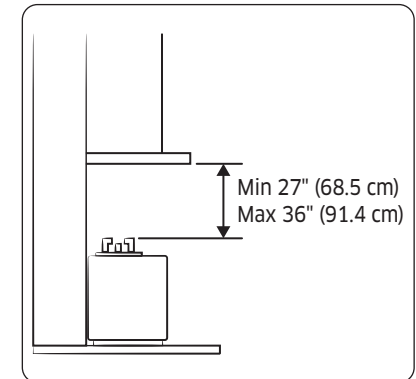

GAS RANGES

Installation Requirements

Venting Methods

Smoke is exhausted to the outside through a special pipe connected to the hood.

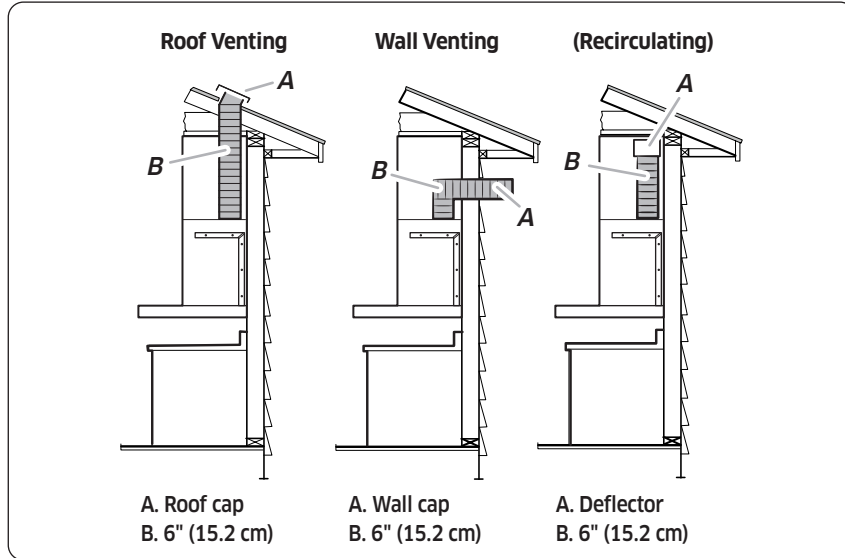

⚠ CAUTION

- The minimum connectable exhaust outlet diameter is 6" (15.2 cm).
- Ensure the exhaust outlet diameter and duct diameter match, and then connect the duct to the wall outlet.
- If the duct and the wall outlet have different diameters, the suction performance will decrease while also significantly increasing noise. The manufacturer is not responsible for any problems caused by this.
- Use the minimum possible length for the duct, and do not significantly alter the cross-section.
- When connecting the duct, minimize bending. (Max bending angle: 90°)
- In an environment where installing with an external venting method is possible, be sure to install only using the external venting method.

Parts List

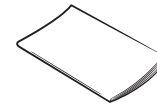

User manual & Installation manual (2)

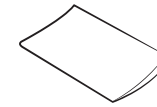

Template for Installation (1)

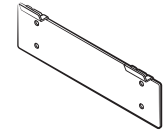

Hood Mounting Bracket (1)

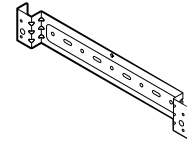

Duct Cover Mounting Bracket (1)

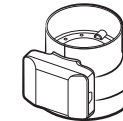

Electric Damper (1)
NK3*CB700W** only

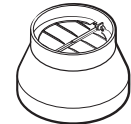

Damper (1)
NK3*CB600W** only

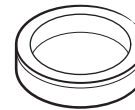

Damper Adapter (1)

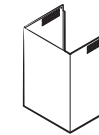

Upper Duct Cover (1)



Lower Duct Cover (1)

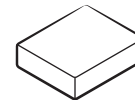

5 mm Magnet (2)



Filter Support Cable * (2)

* To reduce the risk of the filter dropping, assemble the filter support cable to the filter.

Sub-Parts List

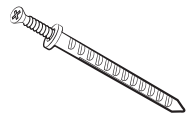

6 × 130 mm
Screw Anchor (2)



6 × 30 mm
Screw Anchor (7)



4 × 10 mm
Hood Fixing Screw (10)



22 mm Washer (4)

NOTE

Install the product by using the included accessories and materials appropriately and according to the installation environment and conditions.

Additional Purchase Accessories

Model	NK30CB600W**, NK36CB600W**
Recirculation Kit	NK-AR7000WB/AA
Charcoal Filter Kit	NK-AF7000WB/AA
Hood Extension Kit	NK-AE6000W*/AA

Needed Parts list (Not Supplied)

- Gloves
- Safety Glasses
- Pencil
- Measuring Tape or Ruler
- Tape to installation Template
- Spirit Level
- Phillips Screwdrivers
- Electric Drill and 1/4" (0.6 cm) drill bits
- Pliers
- Wire cutter/Stripper
- Home Power Supply Cable
- UL listed Wire Nuts (3 pcs)
- UL/CSA approved strain relief
- 6" (15.2 cm) Flexible Duct
- Duct Clamps
- Duct Sealing Tape
- Knife
- Caulking Gun and compound
- Jigsaw, Grinder

Installation Requirements

Installation Clearances

Upper furniture Dimension

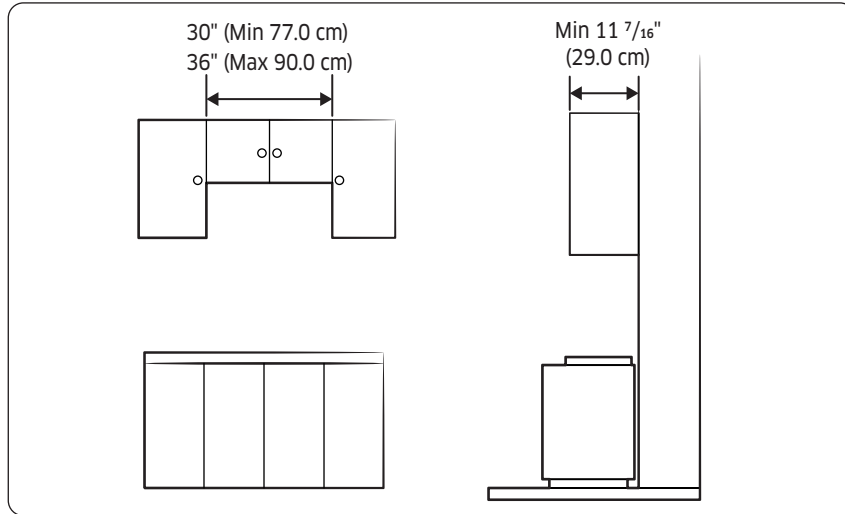

Required Hood installation Height

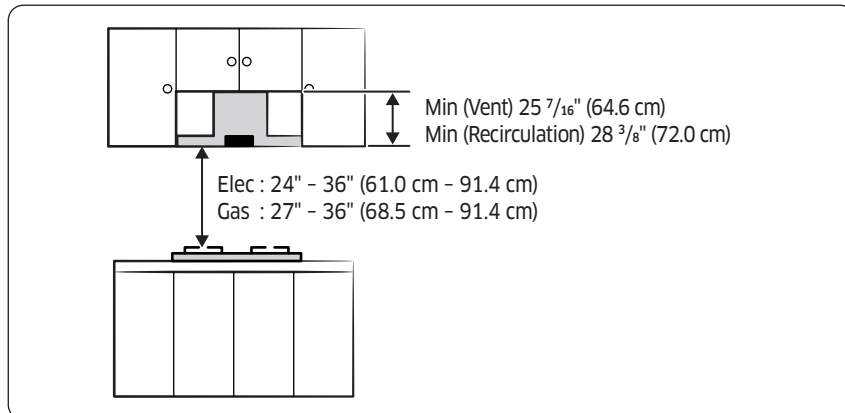

Making a hole in the furniture

Duct hole guide_Op.1

Cabinet floor drilling work: hood exhaust outlet (damper) cutting work

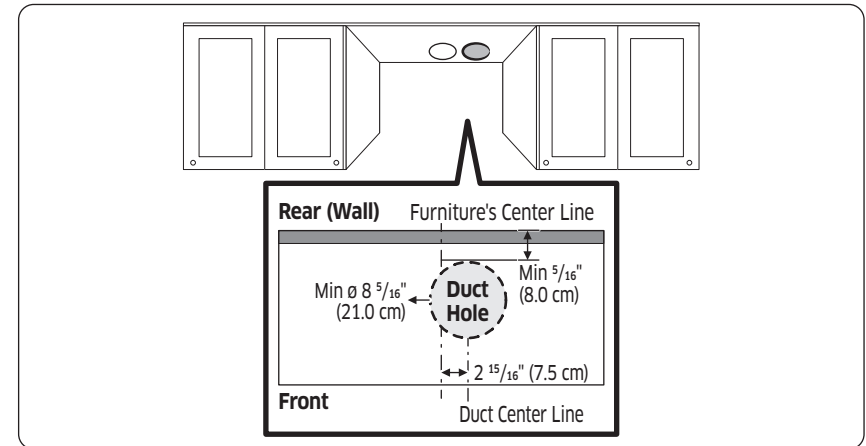

⚠ CAUTION

- Cut the cabinet in a way that does not interfere with the damper outlet.
- After assembling the duct cover, make sure that the cut surface of the cabinet is not exposed. (The hole size must be smaller than the duct cover.)
- Vacuum the sawdust to prevent it from blowing away.
- Make sure the cabinets are not damaged.
- Before cutting the cabinet, explain to the customer that the cabinet needs to be cut, and then obtain consent before proceeding.

Method and sequence of cutting the upper cabinets

1. Refer to the cutting dimensions above and mark the lines to be cut on the cabinet.
2. Use a jigsaw to cut the upper cabinets. When cutting, use a vacuum cleaner to minimize the amount of dust.

Installation Tool

Jigsaw

Duct hole guide_Op.2

Cabinet floor drilling work: hood exhaust outlet (damper) cutting work

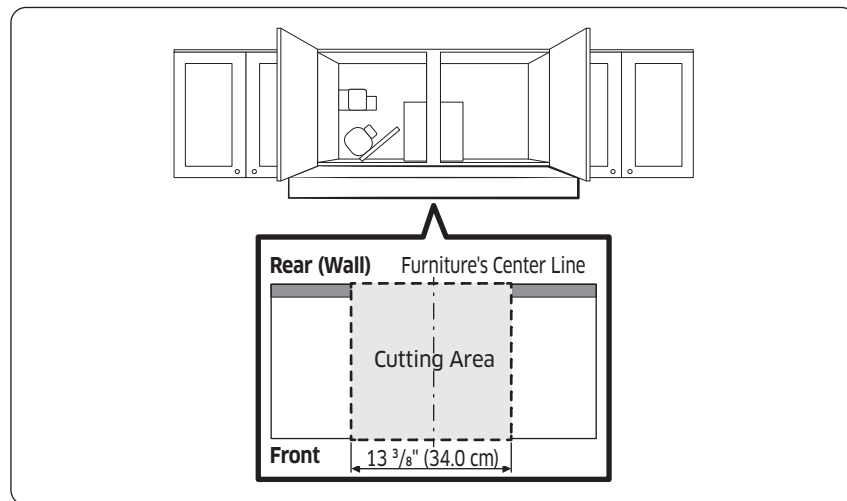

⚠ CAUTION

- Cut the cabinet in a way that does not interfere with the damper outlet.
- Vacuum the sawdust to prevent it from blowing away.
- Make sure the cabinets are not damaged.
- Before cutting the cabinet, explain to the customer that the cabinet needs to be cut, and then obtain consent before proceeding.

Method and sequence of cutting the upper cabinets

1. Refer to the cutting dimensions above and mark the lines to be cut on the cabinet.
2. Use a jigsaw to cut the upper cabinets. When cutting, use a vacuum cleaner to minimize the amount of dust.

Installation Tool

Jigsaw, Grinder

Installation

⚠ CAUTION

- This product must be installed by a professional hood installer.
- If the product is installed on a tiled wall or on drywall, there is a risk of the hood falling, so be sure to fix the fixing screws to the concrete behind the wall.
- Do not attach the product as if it were a tile or fix it with cement, silicone, or adhesive. Install it on a concrete wall using the provided screws.

Setting the Location

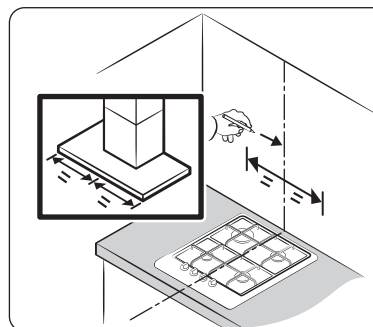

1. Be sure to check that the product you have purchased is suitable for the installation space you have chosen.

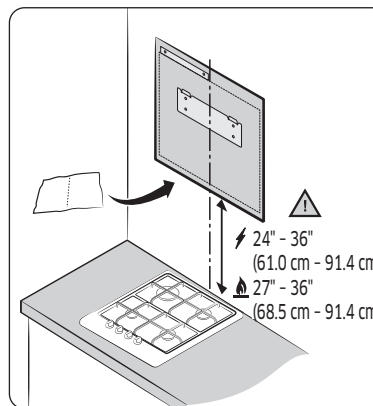

2. Fix the enclosed installation template and then install it so that it does not twist horizontally.

⚠ CAUTION

Please pay attention to the mounting height. The mounting height is measured from the top of the range to the upper cabinets. The mounting height for an electric cooking surface is measured from its glass cooktop. For a gas cooking surface, the mounting height is measured from the top of the burning grates.

Installation

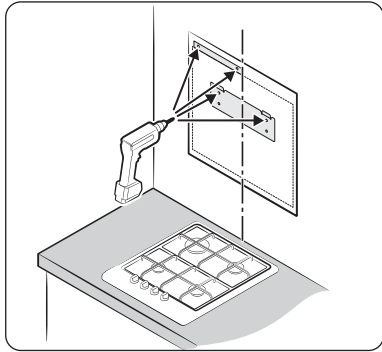

3. Check the position for fixing the hood mounting bracket.

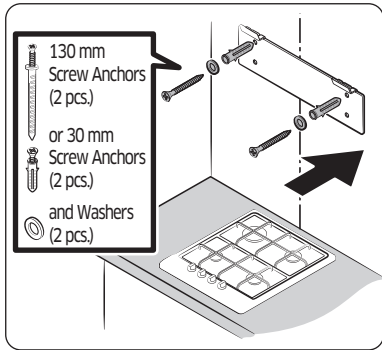

4. Fix the hood mounting bracket horizontally on the wall where the hood is to be installed using screw anchors, hood mounting bracket screws, and washers. Be sure to install it on the wall using the two 30 mm screw anchors.

NOTE

For a secure hold, use a 130 mm screw anchor.

Connecting the Vent System

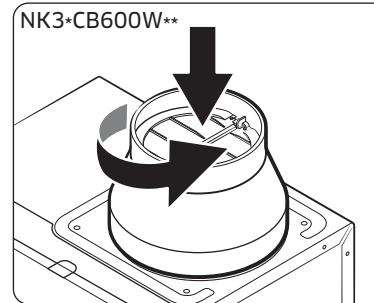

5. Assemble the damper or the electric damper for preventing backflow by turning it in to the hood exhaust outlet.

NOTE

- Damper is provided in NK3*CB600W**.
- Electric Damper is provided in NK3*CB700W**.

CAUTION

Check that the electric damper is seated correctly on the screw thread and there is no tilt. If the electric damper is not flush, air will leak through the gap.

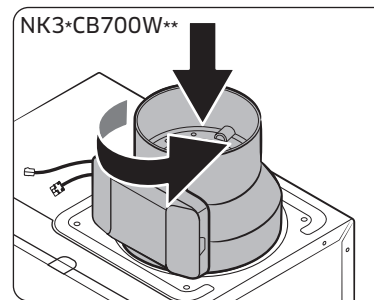

6. Assemble the damper adapter, pushing it into a damper or electric damper. Fix it using tape.

NOTE

- If the hood is NK3*CB600W**, please follow it from No.10.
- If the hood is NK3*CB700W**, please follow it from No.7.

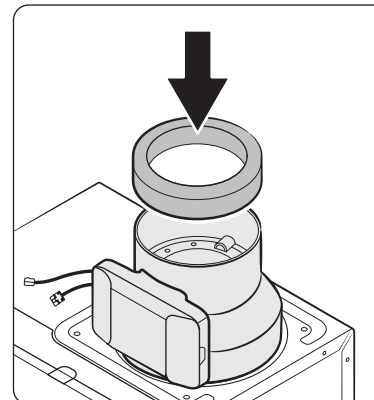

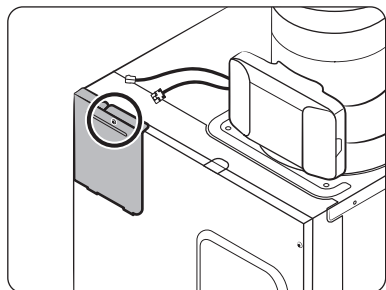

7. Remove the cover by loosening the screw on the PCB cover.

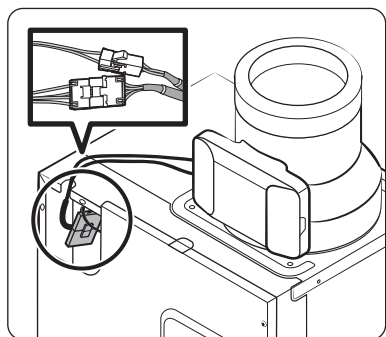

8. Connect the connector of the electric damper wire and the PCB connector.

NOTE

Insert the wire into the hole at the top left corner.

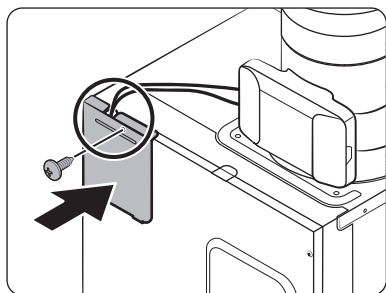

9. Assemble the PCB cover using a screw.

NOTE

Put the connected connector into the hole of the cover as shown in the picture.

Installing the Range Hood

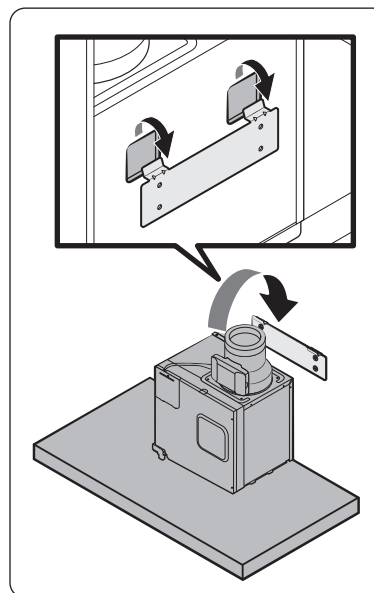

10. Fix the hood to the hood mounting bracket installed on the wall.

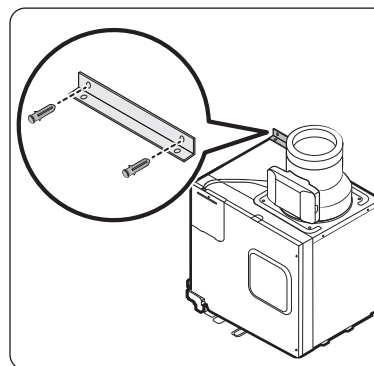

11. Fix the duct auxiliary bracket using two 30 mm screw anchors in the top left of the duct.

Installation

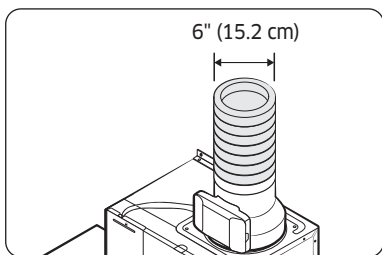

12. Fix the Flexible Duct (6" (15.2 cm)) to the hood outlet and the vent on the wall, respectively, with tape.

⚠ CAUTION

- Ensure the exhaust outlet diameter and duct diameter match, and then connect the duct to the wall outlet.
- If the duct and the wall outlet have different diameters, the suction performance will decrease while significantly increasing noise. The manufacturer is not responsible for any problems caused by this.
- Use the minimum possible length for the duct, and do not significantly alter the cross-section.
- Minimize bending when connecting the duct (max bending angle: 90 degrees).

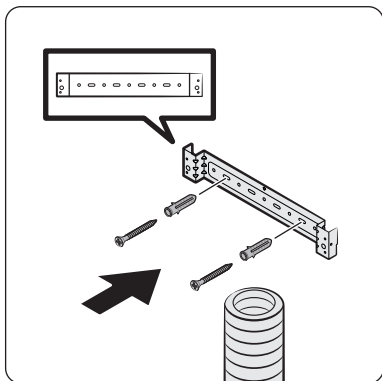

13. Fix the duct cover mounting bracket to the ceiling or rear wall with the 30 mm screw anchors.

⚠ CAUTION

- Install the upper duct closely to the ceiling and upper cabinets.
- Be careful not to let the upper duct come into contact with the upper cabinet door.

Electrical Connection

⚠ WARNING

Assembly and electrical connections must be carried out by qualified technician.

⚠ WARNING



Electrical Shock Hazard

Turn off power circuit at the service panel before wiring this unit.

120 VAC, 15 or 20 Amp circuit required.

Failure to do so can result in death or electrical shock.

Connect ground wire to Green/Yellow ground wire in terminal box.

To protect you against electric shock, The Green/Yellow Wire must be connected to the grounding wire in home electrical system.

Failure to do so can result in death or electrical shock.

It must under no circumstances be cut or removed.

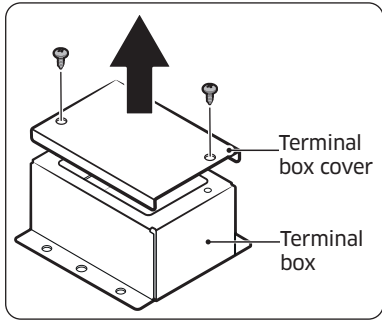

- 14-1. Disconnect power circuit breaker.
- 14-2. Remove terminal box cover.

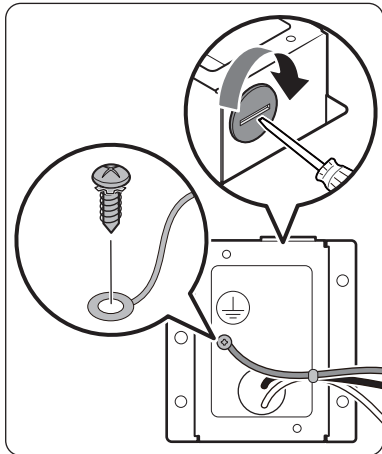

- 14-3. Remove the strain relief hole cover in the terminal box and install a UL/CSA approved strain relief.

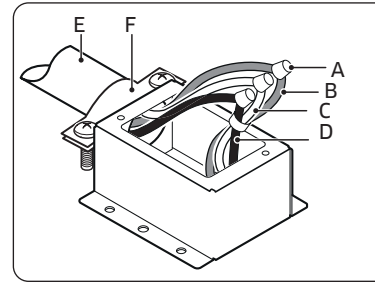

- A. UL listed wire nuts
- B. Green (or bare) wire connected to green/yellow wires
- C. White wires
- D. Black wires
- E. Home power supply cable
- F. UL/CSA approved strain relief

- 14-4. Run home power supply wiring through strain relief into terminal box.
- 14-5. Use UL listed wire nuts and connect white wires (C) together.
- 14-6. Use UL listed wire nuts and connect black wires (D) together.
- 14-7. Connect green (or bare) ground wire from home power supply to the green/yellow ground wire (B) in terminal box using UL listed wire nuts.
- 14-8. Tighten strain relief screw.

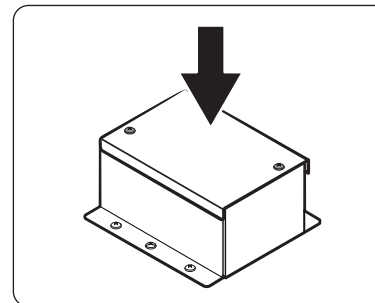

- 14-9. Put the wires into the terminal box and install terminal box cover.
- 14-10. Reconnect power circuit breaker.

Installation

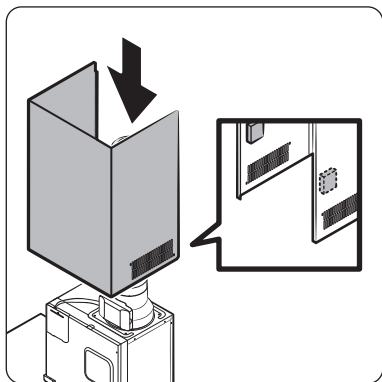

15. Attach each magnet to the inner surface of the upper duct cover overlapping the lower duct cover, and assemble the upper duct cover in a way that it fits the mounting bracket.

⚠ WARNING

Installation with screws or brackets other than those specified in the instruction of this manual may result in electrical hazards.

📄 NOTE

Magnets are included in the accessory box.

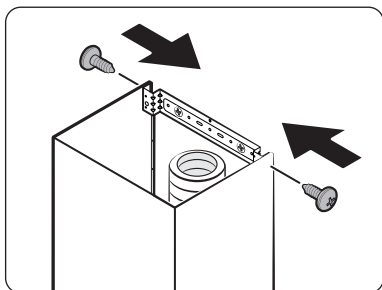

16. Assemble with 10 mm hood fixing screws from both sides.

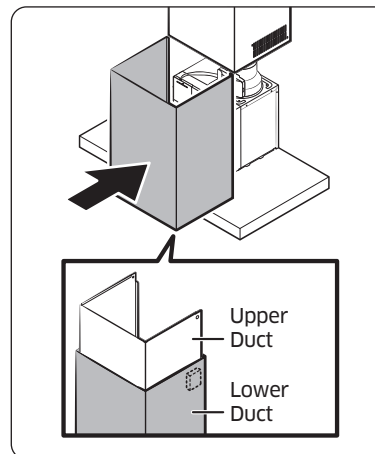

17. Assemble the lower duct cover to the hood. Magnets on the upper duct cover hold the lower duct cover in place.

📄 NOTE

The magnet must be attached to the upper line of the lower duct.

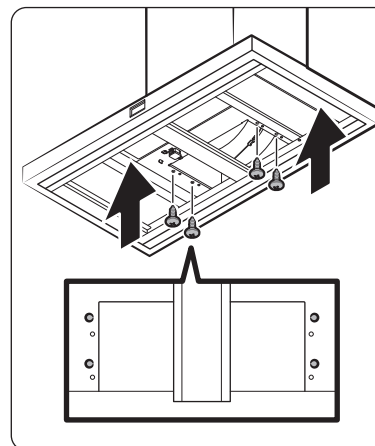

18. Remove the filter at the bottom of the hood. Assemble the lower duct cover by fitting a 10 mm hood fixing screw to the hole in the lower duct cover.

⚠ CAUTION

When removing the filter, use both hands to avoid dropping the filter.

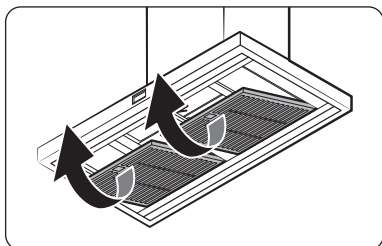

19. When the lower duct cover assembly is complete, reassemble the filter in the reverse order of disassembly.

NOTE

To install the extension kit, follow same process.

WARNING

Be sure to use an outlet with a ground terminal for safety. This can prevent the risk of electric shock, fire, or malfunction. If the outlet does not have a ground terminal, purchase a separate grounding wire and connect it to the grounding line.

CAUTION

Do not ground on gas pipes, water pipes, telephone lines, etc.

NOTE

Be sure to install a short-circuit breaker where there is a risk of a short circuit.

Connect the filter support cable

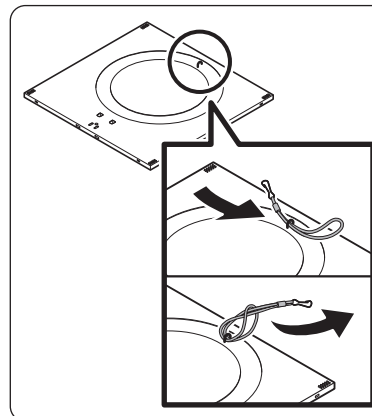

1. Remove the filter at the bottom of the hood. Pass the filter support cable through the wire loop attached on the top of the filter. Make the knot by passing the hook of the filter support cable through the other end of the filter support cable.

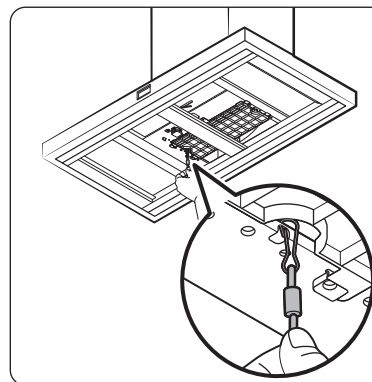

2. Hang the hook of the filter support cable to the anchor at bottom of the hood. Assemble the filter.

Installation

Installing the Recirculation Kit

NOTE

Same process until No. 14

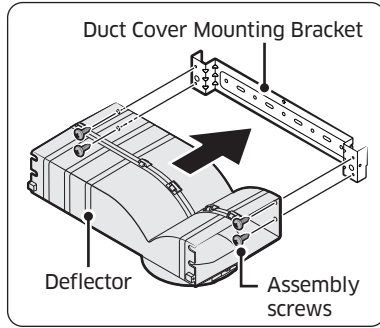

1. Assemble the air deflector with the duct cover mounting bracket with the four assembly screws provided with the Recirculation Kit.

NOTE

- Use of recirculation type hoods in closed spaces may cause poor ventilation performance.
- Please ventilate the room by opening the windows while operating the device.

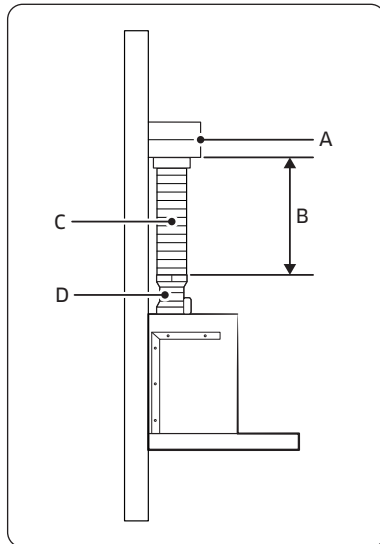

2. Measure from the bottom of the deflector to the bottom of the hood outlet.
3. Cut the duct to the measured size "X."
4. Remove the deflector.
5. Slide the duct onto the bottom of the deflector.
6. Place the assembled deflector and duct over the exhaust outlet from the hood.
7. Reassemble the air deflector to the duct cover mounting bracket with the four assembly screws.
8. Seal the connections with tape.

A	Deflector
B	X = length to cut duct
C	Duct
D	Exhaust outlet

Electrical Connection

WARNING

Assembly and electrical connections must be carried out by qualified technician.

WARNING



Electrical Shock Hazard

Turn off power circuit at the service panel before wiring this unit.
120 VAC, 15 or 20 Amp circuit required.

Failure to do so can result in death or electrical shock.

Connect ground wire to Green/Yellow ground wire in terminal box.
To protect you against electric shock, The Green/Yellow Wire must be connected to the grounding wire in home electrical system.

Failure to do so can result in death or electrical shock.
It must under no circumstances be cut or removed.

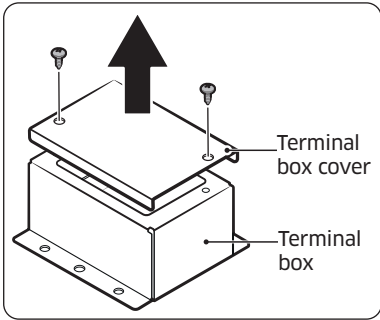

- 9-1. Disconnect power circuit breaker.
- 9-2. Remove terminal box cover.

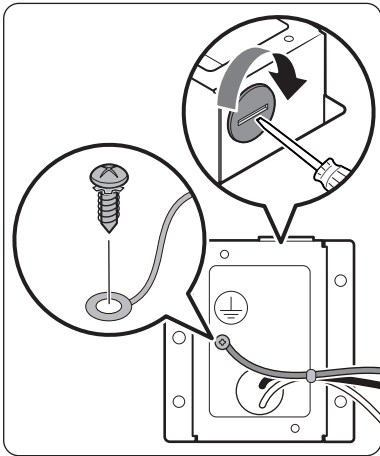

- 9-3. Remove the strain relief hole cover in the terminal box and install a UL/CSA approved strain relief.

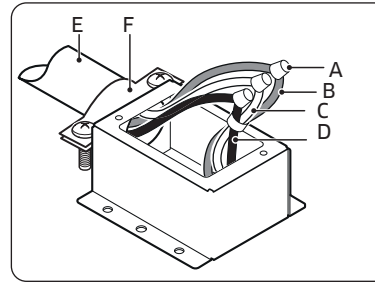

- A. UL listed wire nuts
- B. Green (or bare) wire connected to green/yellow wires
- C. White wires
- D. Black wires
- E. Home power supply cable
- F. UL/CSA approved strain relief

- 9-4. Run home power supply wiring through strain relief into terminal box.
- 9-5. Use UL listed wire nuts and connect white wires (C) together.
- 9-6. Use UL listed wire nuts and connect black wires (D) together.
- 9-7. Connect green (or bare) ground wire from home power supply to the green/yellow ground wire (B) in terminal box using UL listed wire nuts.
- 9-8. Tighten strain relief screw.

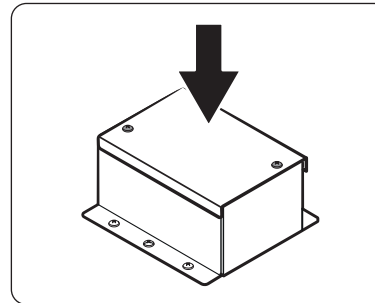

- 9-9. Put the wires into the terminal box and install terminal box cover.
- 9-10. Reconnect power circuit breaker.

Installation

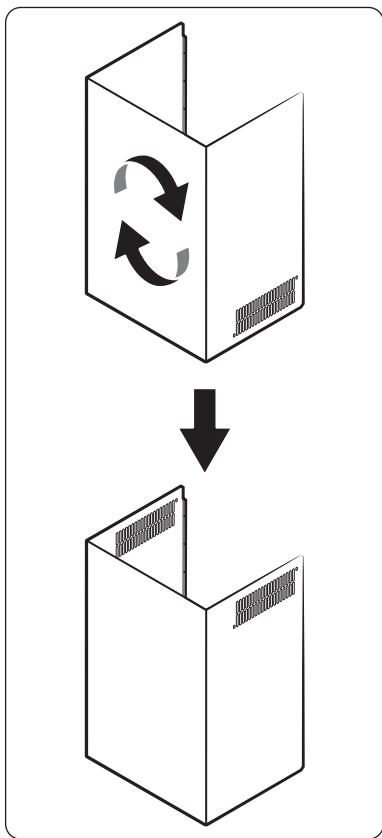

10. Rotate the upper duct as in the picture.

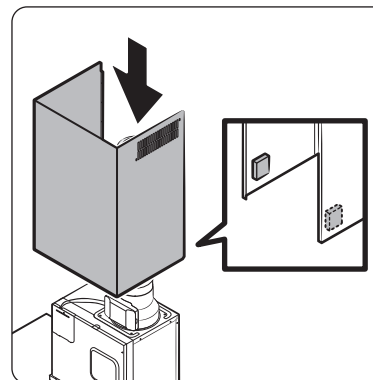

11. Attach each magnet to the inner surface of the upper duct cover overlapping with the lower duct cover, and assemble the upper duct cover in a way that it fits the mounting bracket.

⚠ WARNING

Installation with screws or brackets other than those specified in the instruction of this manual may result in electrical hazards.

📖 NOTE

Magnets are included in the accessory box.

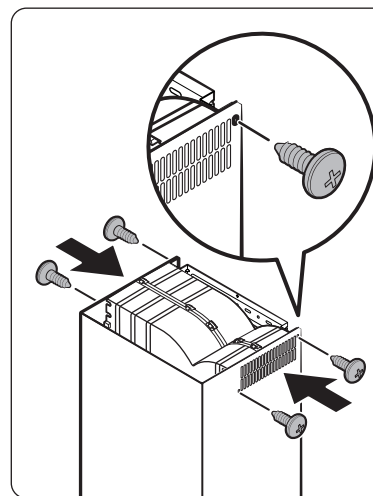

12. Assemble with 10 mm hood fixing screws from both sides.

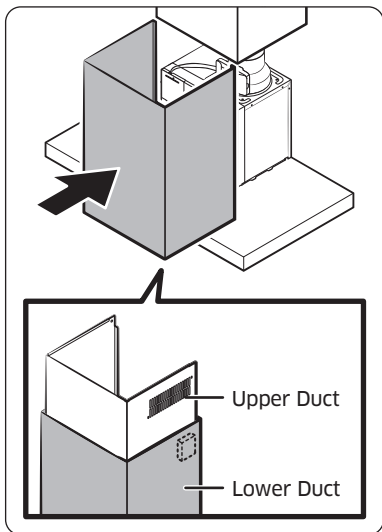

13. Assemble the lower duct cover to the hood. Magnets on the upper duct cover hold the lower duct cover in place.

NOTE

The Magnet must be attached to the upper line of the Lower Duct.

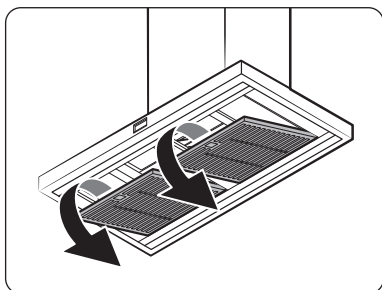

14. Remove metal grease filter from the range hood.

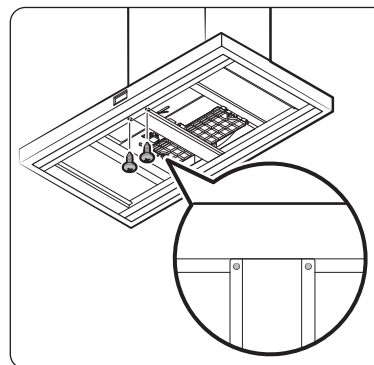

15. Remove the 2 screws from the range hood.

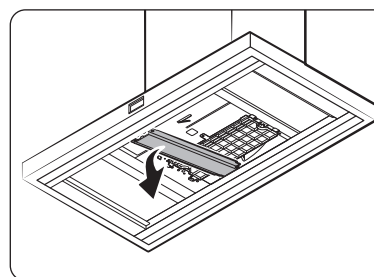

16. Remove the frame middle part from the range hood.

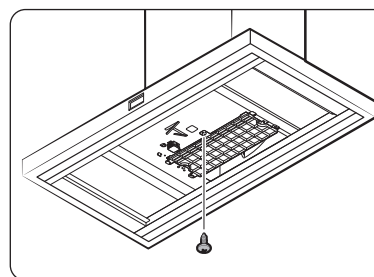

17. Remove one screw from the range hood.

Installation

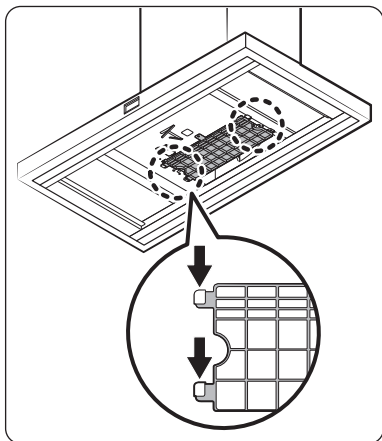

18. Remove the guard by pushing the hook of the guard in the direction of the arrow.

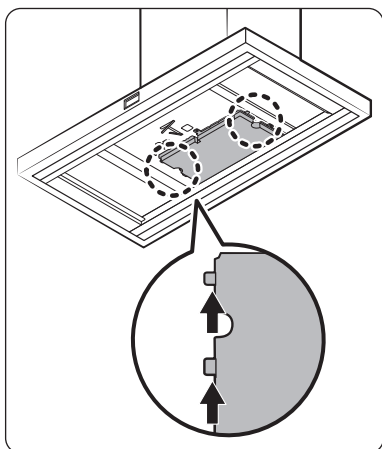

19. Insert the charcoal filter hook by pushing it in the direction of the arrow.

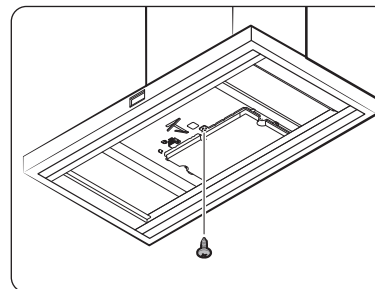

20. Assemble the charcoal filter with the assembly screw provided with the Recirculation Kit. Reassemble the frame middle and filter in the reverse order of disassembly.

Range Hood Description

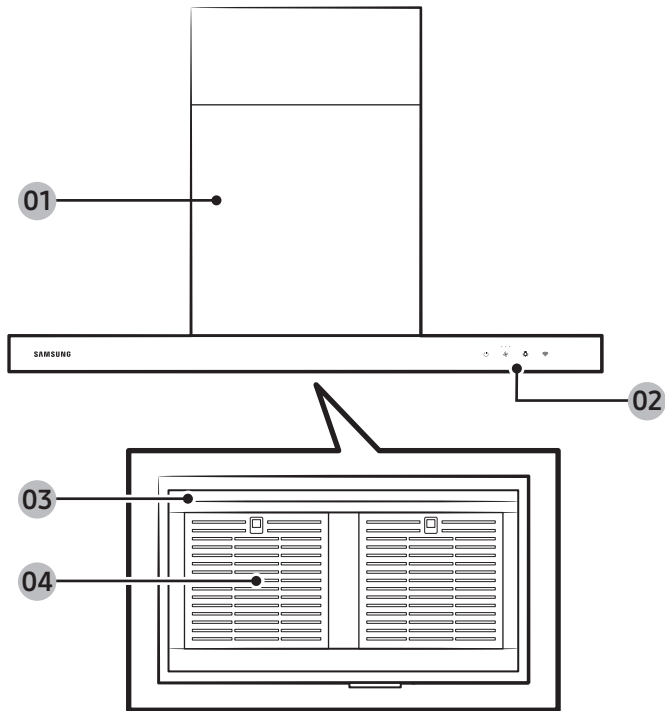

01 Duct

02 Button panel

03 Lamp

04 Filter

Range Hood Overview

Button panel

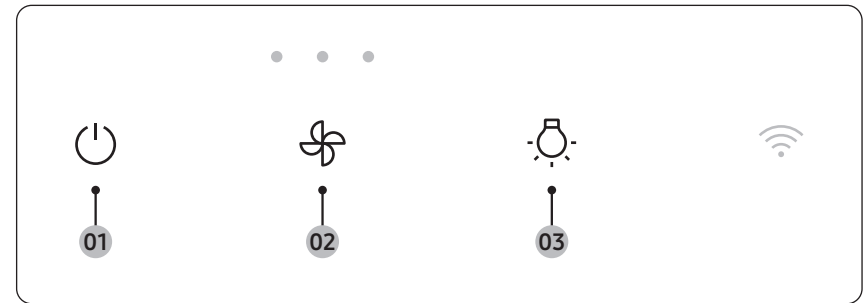

01 Power button

- Short press: Turns the device ON/OFF.

02 Mode button

- Short press: Changes the operation mode. (Low → Medium → High → (Boost))
- 5 second press: Deactivates/activates the Wi-Fi
 - Delay off mode can be activated on the SmartThings app.
 - Filter usage time can be checked on the SmartThings app.
 - The range hood can be operated through automations with registered Samsung products on the SmartThings app.
- 10 second press: Activates/deactivates the Boost mode.

03 Light button

- Short press: Changes the light mode (High → Low → Off)
- 5 second press: Activates/deactivates the AP

Using the Range Hood

Turning the Range Hood On or Off

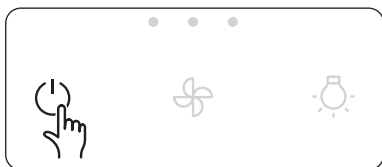

The device turns on with a chime sound, and starts operation in Low mode.

Changing the operation mode

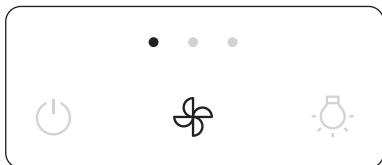
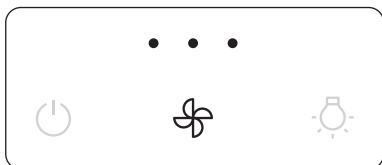
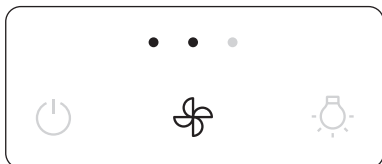
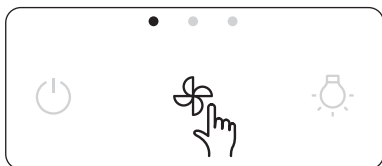



Change the device operation mode as necessary.

- Press the  button to select the operation mode to use.
 - Each time you press the button, the mode changes in the following order: Low → Medium → High → (Boost)

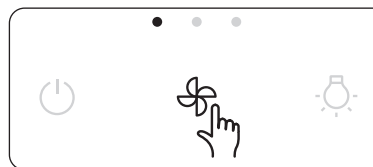
Activates/Deactivates Boost mode



Boost mode is a function that allows powerful exhaust for a short time.

1. Press the  button for 10 seconds.
2. Boost mode has been added. Boost mode (Max 630 CFM) is available.
3. LEDs on the  button are sequentially filled while the Boost mode is on.

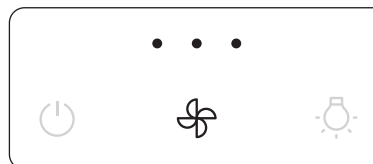
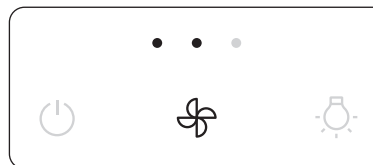
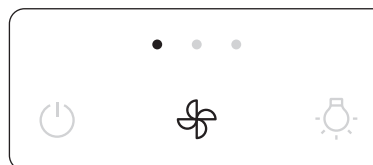

Makeup Air

- When using ventilation systems with greater than the specified CFM of air movement, review local building codes as they may require makeup air systems. Consult an HVAC professional for the specific requirements for your area as the CFM requirements can vary between locales.
- Consult an HVAC professional to select the correct CFM capacity range hood for your application. The CFM capacity depends on the range or cooktop BTU rating, size and location, size of the kitchen, and the range hood ductwork in the kitchen.

⚠ CAUTION

Do not activate this function without a qualified person present. We recommend that a qualified technician install the range hood. It is the installer's responsibility to ensure that the range hood complies with the installation clearances specified for the product. To activate this function's Boost mode, the Make-up air system is required.

Using the lighting

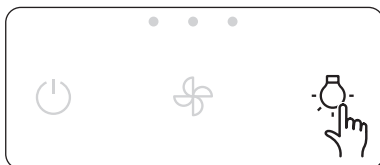

Adjusting the lighting level of the product.

- Press the  button briefly to select the desired lighting step.
 - It repeats in the order of High → Low → Off.

Wi-Fi On/Off

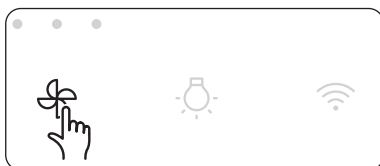

This feature turns the product's Wi-Fi on or off.

- Press the  button for 5 seconds. Press the  button again for 5 seconds to turn on Wi-Fi.

Automatic operation to prevent range hood overheating

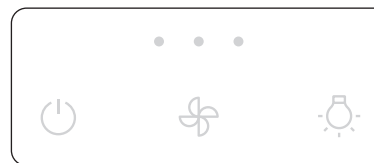

This feature prevents overheating when the hood is turned off.

- When the hood temperature rises, the middle LED on the mode button blinks, and it operates in Medium mode.
- If the hood temperature stabilizes or the  button is pressed, the hood is turned off.

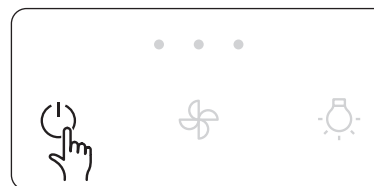

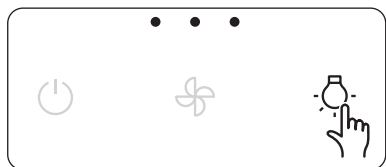

Using the Range Hood

Entering AP(Access Point)

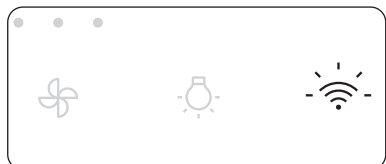

1. Press the  button for 5 seconds as instructed in the app.



2. When in AP mode, the  icon blinks. Please proceed with the connection according to the mobile guide.

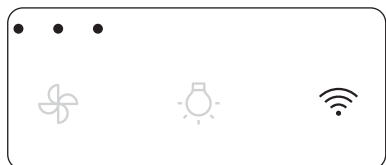

3. When the connection is completed,  icon remains on.

Delay off

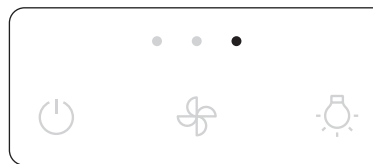
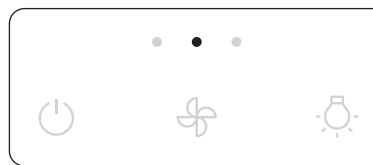
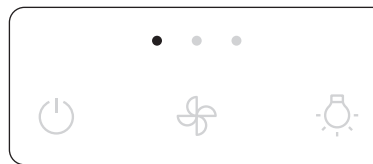
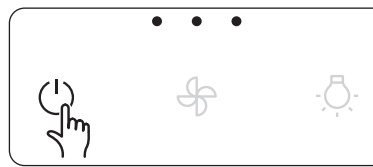

Delay off is a function that vents the remaining pollutants in the kitchen after cooking and operates after the hood is turned off.

- If you set the delay off function in the SmartThings app and turn off the working hood, the delay off function will work.
- LEDs on the  button are turned on sequentially while the delay off function is in operation.
- The unit will operate for 3 minutes in Low mode and then turns off automatically.

NOTE

Delay off mode can be used only when the hood is connected to the SmartThings app.

Error indication

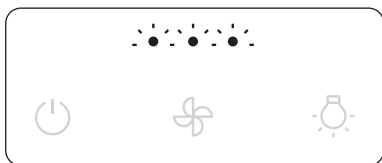

- When a product error occurs, all LEDs on the  button blink.
- Errors and actions can be found in the SmartThings app.
- If the problem persists, disconnect the power for at least 30 seconds, cool the product sufficiently, and restart it.
 - If this problem is not solved, contact a Samsung Electronics Service Center.

NOTE

Check error code function can be used only when the hood is connected to the SmartThings app.

Bixby

- Bixby is the name of Samsung's artificial intelligence solution and it makes it possible to control the product by voice.
- To use the voice recognition function, you need to connect the SmartThings app and the product on your smartphone.
- For models that do not directly recognize voice input for the product after connecting to the app, some functions can still be controlled through Bixby on Samsung smartphones.

Amazon Alexa & Google Assistant

Samsung smart home appliances are supported by SmartThings skill in Alexa & action in Google Assistant.

Installation Guide

Here's how to link SmartThings account into Amazon Alexa or Google Assistant. SmartThings App and Alexa App (or Google Assistant App) should be installed on your phone.

1. Setup supported devices on SmartThings
2. After device setup, tap **'Voice assistant'** and link your Samsung account to Amazon Alexa. (or Google Assistant)
3. Check that the devices are visible on Amazon Alexa app. Then account linking is complete. (Check that the devices are visible and set the location (home & room) of devices in Google home app. Then account linking is complete.)

Cleaning and Maintenance

Cleaning the range hood

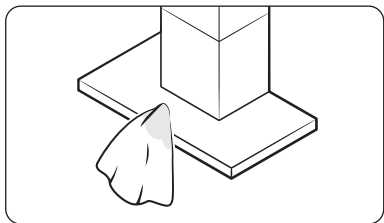

Wipe the front of the product with a soft cloth soaked in neutral liquid detergent.

⚠ CAUTION

- Do not use rough materials such as sponges.
- Do not use baking soda, percarbonate, citric acid, abrasives, alcohol, etc. The surface coating may be damaged or discolored.
- When cleaning, always wear gloves for safety.
- Be sure to turn off the power when cleaning the hood.
- There is a risk of fire if it is not cleaned according to the user manual.

Cleaning the Filters

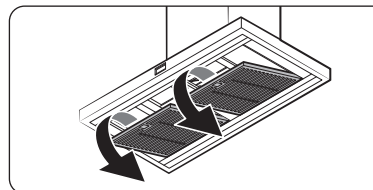

1. Please remove the filter at the bottom of the hood.

⚠ CAUTION

When separating the filter, use both hands to separate it carefully so that it does not drop.

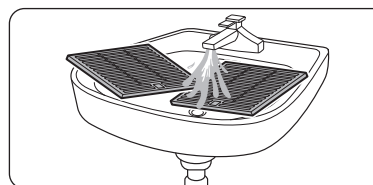

2. Soak the filter in lukewarm water with neutral detergent for about 10 minutes, then rinse it with water and clean it.

⚠ CAUTION

Do not use a scrubber to clean the filter.

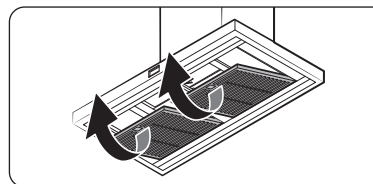

3. When cleaning is complete, reassemble the filter in the reverse order of disassembly.

📖 NOTE

Put the filter into the dishwasher and clean it conveniently with a standard wash cycle.

⚠ CAUTION

- Filters should be cleaned by hand with neutral detergent once a month, and if washed with a dishwasher, they should be washed for only a short time at a low temperature.
- Filters may discolor during cleaning, but this does not affect performance.
- Do not spray water directly on the filter while mounted on the hood. There is a risk of electric shock and fire.
- The front of the filter is made of stainless steel. Please be careful with it.
- Be sure to wear gloves because the edge of the filter can be sharp and cause injury.

Replacing the LED Lamp

This product is equipped with a dedicated LED lamp. If you need a replacement, please contact the service center.

SmartThings app

To use the SmartThings app, connect the product to the network in the sequence described below. The images shown may differ depending on your smartphone model, OS version, and manufacturer. You can only set up the Wi-Fi access point when connecting the product to a Wi-Fi network. Once the product is connected, you can use the SmartThings app via Wi-Fi, 3G, LTE, 5G or other wireless networks. If the Wi-Fi disconnects, please follow the instructions in the Samsung SmartThings app via your mobile device or tablet. You can easily install the SmartThings app or use the product with your smartphone by scanning the QR code on the attached label.

1 Checking the power connections

Check if the power is connected to the product and the access point.

2 Setting up and connecting to a Wi-Fi access point using your smartphone

1. To connect the product to a Wi-Fi network, turn on Wi-Fi in "Settings > Wi-Fi", and then select the access point that you wish to connect to.

- Only alphanumeric characters are supported for wireless access point names (SSIDs). If an SSID has a special character, rename it before connecting to it.
- This product supports only **2.4 GHz** Wi-Fi.



2. Turning off "Switch to Mobile Data" in "Settings > Wi-Fi" on Your Smartphone

- If "Switch to mobile data" or "Adaptive Wi-Fi" is turned on, you cannot connect to the network. Be sure to turn off these functions before connecting to the network.

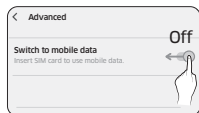

NOTE

The setup may differ depending on your smartphone model, OS version, and manufacturer.

3. Checking Internet Connectivity

- After connecting to Wi-Fi, check that your smartphone is connected to the Internet.

NOTE

A firewall may prevent your smartphone from connecting to the Internet. Contact your Internet service provider for troubleshooting.

3 Downloading the SmartThings app and registering your Samsung account

1. Downloading the SmartThings app

- Search for "SmartThings" in the Play Store or App Store, and download the SmartThings app to your smartphone.
- If the SmartThings app is already installed on your smartphone, update it to the latest version.



SmartThings (Samsung Connect)
Samsung Electronics Co., Ltd.

NOTE

- The SmartThings app supports Android 7.0 or later (with at least 2 GB RAM) and iOS 12.0 or later. The app is optimized for iPhone 6s or later and Samsung smartphones (Galaxy S and Note series). The updates of the SmartThings app or the functions supported by it may be discontinued for the previously supported OS versions due to issues like usability and security.
- The SmartThings app may change without prior notice to improve product usability and performance.

2. Registering your Samsung account

- A Samsung account is required to use the SmartThings app. To create a Samsung account and log in to your account, follow the instructions displayed on the SmartThings app. You do not need to install an additional app.

NOTE

- If you already have a Samsung account, log in to the account. If you have a smartphone that is a Samsung device and you have a Samsung account, your smartphone is automatically logged in to your account.
- If you log in from a smartphone produced for another country, you need to log in with its country code when you create your Samsung account, and the SmartThings app may not be usable on some smartphones.

SmartThings app

4 Connecting the SmartThings app to your product

1. Selecting the product that you want to connect.

- 1) Start the SmartThings app about one minute after turning on the hood.
- 2) After the SmartThings app is started, select "ADD NOW" when a pop-up window saying that a product is found appears.

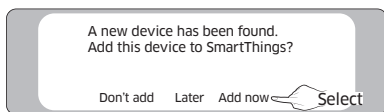

- 3) If the pop-up window does not appear, select "+," and then "Add Device."



You can add a product you want to connect to by selecting it manually or by selecting "Scan."

- Select manually: Range Hood > Samsung
- Scan: [Range Hood] Samsung

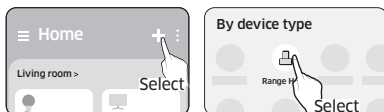

2. Connecting the SmartThings app to your product

- Follow the instructions displayed on the SmartThings app to connect to your product.
- For information on how to use the SmartThings app, select the How To menu in the app.

NOTE

- If any pop-up-window appears on the top of the smartphone while connecting to your product, do not select it.
- If a pop-up window saying that the device is already registered appears while connecting to your product, get permission using "REQUEST PERMISSION" from a user already connected to the product, or create a new account using "REGISTER MY ACCOUNT" to independently connect to the product.
- If a Samsung account-related country error occurs while connecting to your product, log out of your current Samsung account, log in to your previous Samsung account, and then delete all devices that have been previously connected. Then, log in to your current Samsung account again and configure the settings.

- If a failure message appears while adding a device, see "Setting up and connecting to a Wi-Fi access point using your smartphone" on page 29. The connection may fail temporarily due to an installation location problem with the access point or other problems.
- If the word "AP" does not disappear from the display, turn off the power and turn on it in again.
- For the security protocols for wireless/wired access points, WPA-PSK and WPA2-PSK are recommended. For the authentication method, AES is recommended. New Wi-Fi authentication specifications and non-standard WiFi authentication methods are not supported.
- The product supports the IEEE802.11 b/g/n (2.4 GHz) communication protocol. (Samsung recommends IEEE802.11n.)
- If your Internet service provider has permanently registered the MAC address (a unique identification number) of your PC or modem, you may not be able to connect your product to the Internet. Contact your Internet service provider and ask how to connect devices other than your PC (such as a Range Hood) to the Internet.

Open Source Announcement

The software included in this product contains open source software. You may obtain the complete corresponding source code for a period of three years after the last shipment of this product by contacting our support team via <http://opensource.samsung.com> (please use the "Inquiry" menu). It is also possible to obtain the complete corresponding source code in a physical medium, such as CD-ROM. A minimal payment will be required.

The following URL http://opensource.samsung.com/opensource/SMART_AT_051/seq/0 leads to the open source license information as related to this product. This offer is valid to anyone in receipt of this information.



Troubleshooting

If you suspect there is a failure while using the product, check the following before requesting service from the service center. When you request service, you will be charged for the visit and diagnosing the symptoms even if the product is not broken.

CAUTION

If you require repairs, disconnect the power circuit breaker immediately and contact the service center. The following information is required when requesting service.

- Model number and serial number (find by removing the filter, listed inside product)
- Product warranty details
- Explanation of the problem

General

Problem	Cause	Action
It's not working.	Is the power being supplied like normal?	Please check if there is a power outage. Please check status of power wires connection.
	Is there any moisture on the exterior of the product?	Please remove moisture from the product.
	Are there any foreign substances on the exterior of the product?	Please wipe off all foreign matter.

Hood Operation

Problem	Cause	Action
The hood's wind strength is weak.	Is there a lot of foreign matter in the filter?	Wipe off the filter with a neutral detergent in lukewarm water.

Information codes

Code	Description	Action
C121	Temperature sensor is not working	Press the POWER  button to restart the product. If the problem persists, disconnect the power for more than 30 seconds. Allow the product to cool and restart it. If it is not resolved, please contact a Samsung Electronics Service Center.
C154	Main PBA communication is not working with Inverter PBA	
C162	Only occurs when EEPROM Read or Write is not working.	
C163	If you need to check the option code	
C203	Inverter PBA communication is not working with Main PBA	

Troubleshooting

Code	Description	Action
C446	BLDC Motor or Inverter PBA is not working	Press the POWER  button to restart the product. If the problem persists, disconnect the power for more than 30 seconds. Allow the product to cool and restart it. If it is not resolved, please contact a Samsung Electronics Service Center.
C447		
C455		
C478		
C486		
C489		
C493		
C496		
C499		
C654	Electric Damper is not working	Reconnect the electric damper and check if any foreign matter is on the damper.

Warranty (USA)

Samsung RANGE HOOD

LIMITED WARRANTY TO ORIGINAL CONSUMER PURCHASER WITH PROOF OF PURCHASE

This Samsung brand product, as supplied and distributed by Samsung Electronics America, Inc. (Samsung) and delivered new, in the original carton to the original consumer purchaser, is warranted by Samsung against manufacturing defects in materials and workmanship for a limited warranty period of:

ONE (1) YEAR PARTS AND LABOR

This limited warranty begins on the date of delivery to the original consumer purchaser, and is valid only on products purchased and used in the United States that have been installed, operated, and maintained according to the instructions attached to or furnished with the product. To receive warranty service, the purchaser must contact Samsung at the address or phone number provided below for problem determination and service procedures. Warranty service can only be performed by a Samsung authorized service center. The original dated bill of sale and/or proof of delivery must be presented upon request as proof of purchase to Samsung or Samsung's authorized service center to receive warranty service.

Samsung will provide in-home service within the contiguous United States during the warranty period at no charge, subject to the availability of Samsung authorized servicers within the customer's geographic area. If in-home service is not available, Samsung may elect, at its option, to provide transportation of the product to and from an authorized service center. If the product is located in an area where service by a Samsung authorized servicer is not available, you may be responsible for a trip charge or required to bring the product to a Samsung authorized service center for service.

To receive in-home service, the product must be unobstructed and accessible to the service agent.

During the applicable warranty period, the product will be repaired, replaced, or the purchase price refunded, at the sole option of Samsung. Samsung may use new or reconditioned parts in repairing a product, or replace the product with a new or reconditioned product. Replacement parts and products are warranted for the remaining portion of the original product's warranty or ninety (90) days, whichever is longer. All replaced parts and products are the property of Samsung and you must return them to Samsung.

This limited warranty covers manufacturing defects in materials and workmanship encountered in normal household, noncommercial use of this product and shall not cover the following: damage that occurs in shipment, delivery, installation, and uses for which this product was not intended; damage caused by unauthorized modification or alteration of the product; products where the original factory serial numbers have been removed, defaced, changed in any way, or cannot be readily determined; cosmetic damage, including scratches, dents, chips, and other damage to the product's finishing; damage caused by abuse, misuse, pest infestations, accidents, fire, floods or other acts of nature or God; damage caused by use of equipment, utilities, services, parts, supplies, accessories, applications, installations, repairs, external wiring or connectors not supplied or authorized by Samsung; damage caused by an incorrect electrical line current, voltage, fluctuations, and surges; damage caused by failure to operate and maintain the product according to instructions; in-home instruction on how to use your product; and service to correct installation not in accordance with electrical or plumbing codes or correction of household electrical infrastructure or plumbing (i.e., house wiring, fuses, or water inlet hoses). The cost of repair or replacement under these excluded circumstances shall be the customer's responsibility.

Visits by an authorized servicer to explain product functions, maintenance, or installation is not covered by this limited warranty. Please contact Samsung at the number below for assistance with any of these issues.

EXCLUSION OF IMPLIED WARRANTIES

IMPLIED WARRANTIES, INCLUDING THE IMPLIED WARRANTIES OF MERCHANTABILITY OR FITNESS FOR A PARTICULAR PURPOSE, ARE LIMITED TO ONE YEAR OR THE SHORTEST PERIOD ALLOWED BY LAW. Some states do not allow limitations on how long an implied warranty lasts, so the above limitations or exclusions may not apply to you. This warranty gives you specific rights, and you may also have other rights, which vary from state to state.

LIMITATION OF REMEDIES

YOUR SOLE AND EXCLUSIVE REMEDY IS PRODUCT REPAIR, PRODUCT REPLACEMENT, OR REFUND OF THE PURCHASE PRICE AT Samsung's OPTION, AS PROVIDED IN THIS LIMITED WARRANTY. Samsung SHALL NOT BE LIABLE FOR SPECIAL, INCIDENTAL OR CONSEQUENTIAL DAMAGES INCLUDING BUT NOT LIMITED TO TIME AWAY FROM WORK, HOTELS, AND/OR RESTAURANT MEALS, REMODELING EXPENSES, LOSS OF REVENUE OR PROFITS, FAILURE TO REALIZE SAVINGS OR OTHER BENEFITS, REGARDLESS OF THE LEGAL THEORY ON WHICH THE CLAIM IS BASED, EVEN IF Samsung HAS BEEN ADVISED OF THE POSSIBILITY OF SUCH DAMAGES. Some states do not allow exclusions or limitations of incidental or consequential damage, so the above limitations or exclusions may not apply to you. This warranty gives you specific legal rights, and you may also have other rights which vary from state to state.

Samsung does not warrant uninterrupted or error-free operation of the product. NO WARRANTY OR GUARANTY GIVEN BY ANY PERSON, FIRM, OR CORPORATION WITH RESPECT TO THIS PRODUCT SHALL BE BINDING ON Samsung.

To obtain warranty service, please contact Samsung at:

**1-800-SAMSUNG (726-7864) or
www.samsung.com/us/support**

Warranty (CANADA)

Samsung RANGE HOOD

LIMITED WARRANTY TO ORIGINAL PURCHASER

This Samsung brand product, as supplied and distributed by Samsung Electronics Canada, Inc. (Samsung) and delivered new, in the original carton to the original consumer purchaser, is warranted by Samsung against manufacturing defects in materials and workmanship for a limited warranty period of:

ONE (1) YEAR PARTS AND LABOR

This limited warranty begins on the original date of purchase, and is valid only on products purchased and used in CANADA. To receive warranty service, the purchaser must contact Samsung to determine the problem and service procedures. Warranty service can only be performed by a Samsung authorized service center. The original dated bill of sale must be presented upon request as proof of purchase to Samsung or Samsung's authorized service center.

Samsung will repair or replace this product, at our option and at no charge as stipulated herein, with new or reconditioned parts or products if it is found to be defective during the limited warranty period specified above. All replaced parts and products become the property of Samsung and must be returned to Samsung. Replacement parts and products assume the remaining original warranty, or ninety (90) days, whichever is longer.

In-home service will be provided during the warranty labor period subject to availability within the contiguous Canada.

In-home service is not available in all areas. To receive in home service, the product must be unobstructed and accessible to the service agent. If during in-home service repair can not be completed, it may be necessary to remove, repair and return the product.

This limited warranty covers manufacturing defects in materials and workmanship encountered in normal, noncommercial use of this product and shall not apply to the following, including, but not limited to: damage which occurs in shipment; delivery and installation; applications and uses for which this product was not intended; altered product or serial numbers; cosmetic damage or exterior finish; accidents, abuse, neglect, fire, water, lightning, or other acts of nature; use of products, equipment, systems, utilities, services, parts, supplies, accessories, applications, installations, repairs, external wiring or connectors not supplied or authorized by Samsung which damage this product or result in service problems; incorrect electrical line voltage, fluctuations, and surges; customer adjustments and failure to follow operating instructions, cleaning, maintenance, and environmental instructions that are covered and prescribed in the instruction book; problems caused by pest infestations, and overheating by user. Samsung does not warrant uninterrupted or error-free operation of the product.

THERE ARE NO EXPRESS WARRANTIES OTHER THAN THOSE LISTED AND DESCRIBED ABOVE, AND NO WARRANTIES WHETHER EXPRESS OR IMPLIED, INCLUDING, BUT NOT LIMITED TO, ANY IMPLIED WARRANTIES OF MERCHANTABILITY OR FITNESS FOR A PARTICULAR PURPOSE, SHALL APPLY AFTER THE EXPRESS WARRANTY PERIODS STATED ABOVE, AND NO OTHER EXPRESS WARRANTY OR GUARANTEE GIVEN BY ANY PERSON, FIRM OR CORPORATION WITH RESPECT TO THIS PRODUCT SHALL BE BINDING ON Samsung. Samsung SHALL NOT BE LIABLE FOR LOSS OF REVENUE OR PROFITS, FAILURE TO REALIZE SAVINGS OR OTHER BENEFITS, OR ANY OTHER SPECIAL, INCIDENTAL OR CONSEQUENTIAL DAMAGES CAUSED BY THE USE, MISUSE, OR INABILITY TO USE THIS PRODUCT, REGARDLESS OF THE LEGAL THEORY ON WHICH THE CLAIM IS BASED, EVEN IF Samsung HAS BEEN ADVISED OF THE POSSIBILITY OF SUCH DAMAGES. NOR SHALL RECOVERY OF ANY KIND AGAINST Samsung BE GREATER IN AMOUNT THAN THE PURCHASE PRICE OF THE PRODUCT SOLD BY Samsung AND CAUSING THE ALLEGED DAMAGE. WITHOUT LIMITING THE FOREGOING, PURCHASER ASSUMES ALL RISK AND LIABILITY FOR LOSS, DAMAGE OR INJURY TO PURCHASER AND PURCHASER'S PROPERTY AND TO OTHERS AND THEIR PROPERTY ARISING OUT OF THE USE, MISUSE OR INABILITY TO USE THIS PRODUCT SOLD BY Samsung NOT CAUSED DIRECTLY BY THE NEGLIGENCE OF Samsung. THIS LIMITED WARRANTY SHALL NOT EXTEND TO ANYONE OTHER THAN THE ORIGINAL PURCHASER OF THIS PRODUCT, IS NONTRANSFERABLE, AND STATES YOUR EXCLUSIVE REMEDY.

Memo

Some provinces or territories may or may not allow limitations on how long an implied warranty lasts, or the exclusion or limitation of incidental or consequential damages, so the above limitations or exclusions may not apply to you. This warranty gives you specific legal rights, and you may also have other rights which vary from state to state.

To obtain warranty service, please contact Samsung at:

1-800-SAMSUNG (726-7864) or

www.samsung.com/ca/support (English),

www.samsung.com/ca_fr/support (French)

QUESTIONS OR COMMENTS?

COUNTRY	CALL	OR VISIT US ONLINE AT
U.S.A - Consumer Electronics	1-800-SAMSUNG (726-7864)	www.samsung.com/us/support
CANADA	1-800-SAMSUNG (726-7864)	www.samsung.com/ca/support (English) www.samsung.com/ca_fr/support (French)

